

Junction Box for Select Cameras

FOR USE WITH CAMERA MODELS:

N2IP4D, N2IP4D4MM



N2JB2



Shown with N2IP4D
(Camera not included)

FEATURES:

- Manages & Protects Cables
- 3/4" Conduit Access
- For Indoor & Outdoor Use

SPECIFICATIONS:

	N2JB2
Material	Aluminum Alloy
Color	White
Load Bearing	3 kg (6.61 Lb.)
Product Dimensions	φ110 × 37.3mm (φ4.33 × 1.47")
Product Weight	0.21kg (0.46 Lb.)

PACKAGE INCLUDES:

Item	Qty
Junction box	1
3/4" Conduit Caps	1
Plastic Conduit Cable Connector	1
Gasket	1
Black Rubber Plug	1
Mounting Template	1
Phillips Screws PM4×10mm	3
Mounting Hardware Packet	1

DIMENSIONS:

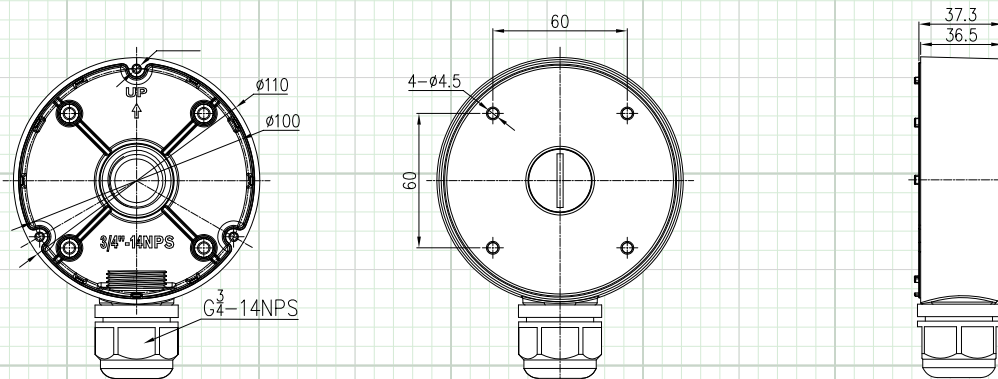

Note: Specification subject to change without notice